



TPC6000-C1564-L/LH

Industrial Panel PC



15.6" high-performance industrial Panel PC

- ◆ Support Intel® the 6/7/8/9th generation Core™i3/i5/i7, Pentium, Celeron CPU
- ◆ LGA1151 socket type CPU. Max.65W TDP



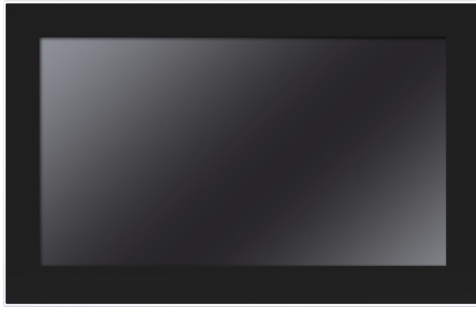

Specification:

System	CPU	Intel® Core™ 6/7/8/9 th generation i7/i5/i3, Pentium/Celeron LGA1151 type CPU. Max.65W TDP
	BIOS	AMI UEFI 128Mbit
	Chipset	H110
	Memory	DDR4-2400MHz, MAX support 32GB
	Storage	1 x M.2 (M Key 2280 PCIe Gen3x4 Lane) , 1 x mSATA
	OS	Windows 7, Windows 7 Embedded, Windows8, Windows10, Windows11, Ubuntu, VXWORKS, QNX
I/O	Network	3 x Intel 10/100/1000Mbps controller, up to 5
	USB	4 x USB3.0 / 2 x USB2.0
	Serial port	4 x RS-232 / RS-485 Interface with surge protection, RS485 support automatic flow control
	Expansion	1 x Mini-PCIe slot
	I/O port	8DI+8DO Wet contact input (24V) , OC gate output (24V 300mA)
	HDMI	HDMI1.2
Physical characteristics	Dimension	405mm * 258mm * 74mm
	Cut out size	387mm * 240mm
	Weight	4.7kg
Power	Input voltage	12-24VDC ±10%, Support reverse connection protection, over voltage protection, over current protection
	Idle Mode Power Consumption	28Watt
LCD	LCD Type	15.6" XGA TFT
	Resolution	1366 x 768/1920*1080
	Colors	16.7MB
	Active Area (W x H)	344.232mm x 193.536mm/344.16mm×193.59mm
	Backlight	LED
	MTBF (hour)	50000hrs/15000hrs
	Pixel Pitch (H x V)	0.252 x 0.252//0.179×0.179
	Luminance	400cd/m2/250cd/m2
	Contrast Ratio	800 : 1/3000:1
	Viewing Angle	(L) 85 / (R) 85 / (T) 50 / (B) 80/(L) 89 / (R) 89 / (T) 89 / (B) 89
Touch screen	Touchscreen type	Capacitive Touchscreen
	Transmittance	≥ 87%
	Response Time (touch pen)	< 5ms
	Surface Hardness	Mohs Hardness 7H
	Click Life	250g / 100,000,000 times
	Multi-touch	10 Points
Environment	Operating Temperature	0 ~ 50°C
	Storage Temperature	-20 ~ 60° C
	Relative Humidity	5~95%@40°C (Non-condensing)
	Vibration	Operating Random Vibration Test 5~500Hz, 1.5Grms@with SSD, follow IEC 60068-2-64
	Shock	Operating 10G peak acceleration (11ms duration), follow IEC 60068-2-27
	EMC	CE/FCC Class B
	Front Panel Protection	IP65 compliant

Dimension: Unit: 405mm * 258mm * 74mm

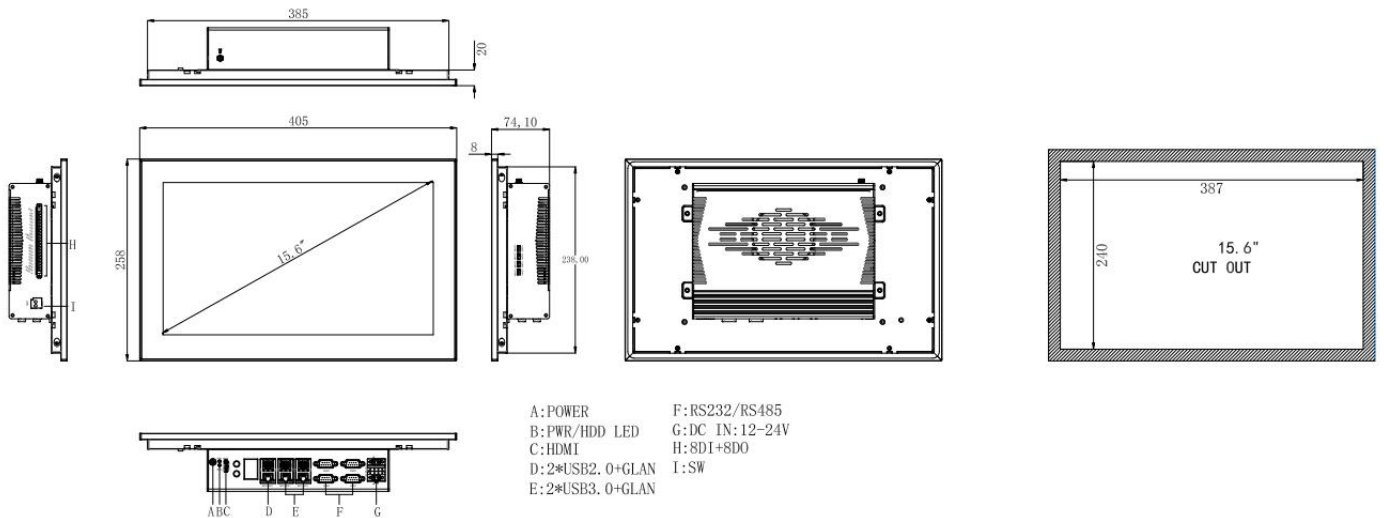

Ordering Information:

Model Name	Description
TPC6000-C1564-L	15.6"LCD, LGA1151 CPU, DDR4 RAM, Mini SATA SSD, Resolution 1366*768, 4 x COM(RS232/485), 3 x GLAN, 6 x USB, 8DIO, DC12~24V, Fan cooling
TPC6000-C1564-LP	15.6"LCD, LGA1151 CPU, DDR4 RAM, Mini SATA SSD, Resolution 1366*768, 4 x COM(RS232/485), 3 x GLAN, 6 x USB, 8DIO, DC12~24V, Fanless
TPC6000-C1564-L5	15.6"LCD, LGA1151 CPU, DDR4 RAM, Mini SATA SSD, Resolution 1366*768, 4 x COM(RS232/485), 5 x GLAN, 6 x USB, 8DIO, DC12~24V, Fan cooling
TPC6000-C1564-L5P	15.6"LCD, LGA1151 CPU, DDR4 RAM, Mini SATA SSD, Resolution 1366*768, 4 x COM(RS232/485), 5 x GLAN, 6 x USB, 8DIO, DC12~24V, Fanless
TPC6000-C1564-LH	15.6"LCD, LGA1151 CPU, DDR4 RAM, Mini SATA SSD, Resolution 1920*1080, 4 x COM(RS232/485), 3 x GLAN, 6 x USB, 8DIO, DC12~24V

Option Items:

Option items	Specification
CPU	Support 6 th /7 th /8 th /9 th generation Intel® Core™ i7/i5/i3 LGA socket type processors Intel® Core™ i3-6100, Dual Core, 3.7GHz, 3MB Cache; Intel® Core™ i3-6100T, Dual Core, 3.2GHz, 3MB Cache; Intel® Core™ i3-7100, Dual Core, 3.9GHz, 3MB Cache; Intel® Core™ i3-8100, Quad Core, 3.6GHz, 6MB Cache Intel® Core™ i5-6400, Quad Core, 2.7GHz, 6MB Cache; Intel® Core™ i5-6500, Quad Core, 3.2GHz, 6MB Cache Intel® Core™ i5-6500T, Quad Core, 2.5GHz, 6MB Cache; Intel® Core™ i5-8400, Six Cores, 2.8GHz, 9MB Cache Intel® Core™ i5-8400T, Six Cores, 1.7GHz, 9MB Cache; Intel® Core™ i7-6700T, Quad Core, 2.8GHz, 8MB Cache Intel® Core™ i7-8700, Six Cores, 3.2GHz, 12MB Cache; Intel® Core™ i7-8700T, Six Cores, 2.4GHz, 12MB Cache Please contact sales to check other request.
Memory	DDR4 4G/8G/16G/32G
Storage	Mini SATA SSD64G/128G/256G/512G/1T
2010300008	120Watt Adapter (Input: 100-240V~50-60Hz 2.0 MAX, Output: +12V—10A)
2030100012	Option EU,US,UK...
5040200002	7260 series (mini PCIe)
4G module	(Quectel EC20,EC25,EG25..)