

## IDP59150-C-HA

■ Arm mounting

### ■ Features

- 15"LCD, 1024x768 resolution, capacitive touch screen.
- Full IP65 design
- DC12-24V power input
- Support ARM mounting from TOP side or BOTTOM side
- Modular button extensions
- Customer-specific requests for button units, up to 6x Ø22 buttons
- 1x power switch and 1x 2in1 USB 2.0 port at the back side



### ■ Specification

Product Name		IDP59150-C-HA
LCD	Size	15"
	Resolution ratio	1024*768
	White Luminance	400cd/m2
	MTBF (hour)	50000hrs
	Contrast Ratio	1000:1
	Viewing Angle	(L)89 / (R)89 / (T)89 / (B)89
Mechanical	Dimensions (W x H x D)	370mm x 338mm x 135mm
	Installation	Swing ARM mounting (Support NODKA 4460 square tube and Rittal CP 40)
	Buttons	Default: 1x Emergency button, 1x selection button, 1x red push button, 1x green push button, 1x Key switch
	Weight	5.1 Kg
System	Display signal Input	ND LINK (RJ45)
	Output	2 x internal USB2.0 (typeA) ,1x 2in1 USB 2.0 at the back of housing
Touch screen	Touch screen type	Capacitive Touch screen
	Communication interface	USB
	Transmittance	≥80%
OS	OS	Windows 7, Windows 10 IoT, Ubuntu, CentOS,
Power Consumption	Input Voltage	12-24VDC ±10% , Support reverse connection protection, over voltage protection, over current protection 1x 2-pins Phoenix Connector for DC power(internal); 1x Power button with light at the back of housing
	Idle Power Consumption	Minimum 15W
Environment	Operating Ambient Temperature	0°C ~ 50°C
	Storage Temperature	-20°C ~ 60°C
	Relative Humidity	5~95% (non-condensing)
	Vibration	SSD applied: 1.5 Grms, IEC 60068-2-64, random, 5 ~ 500 Hz, 1 hr/axis
	Shock	Operating 10G peak acceleration (11ms duration), follow IEC 60068-2-27
	EMC	Class B
	IP rating	Full IP65

## ■ Dimensions (unit : mm) 15"

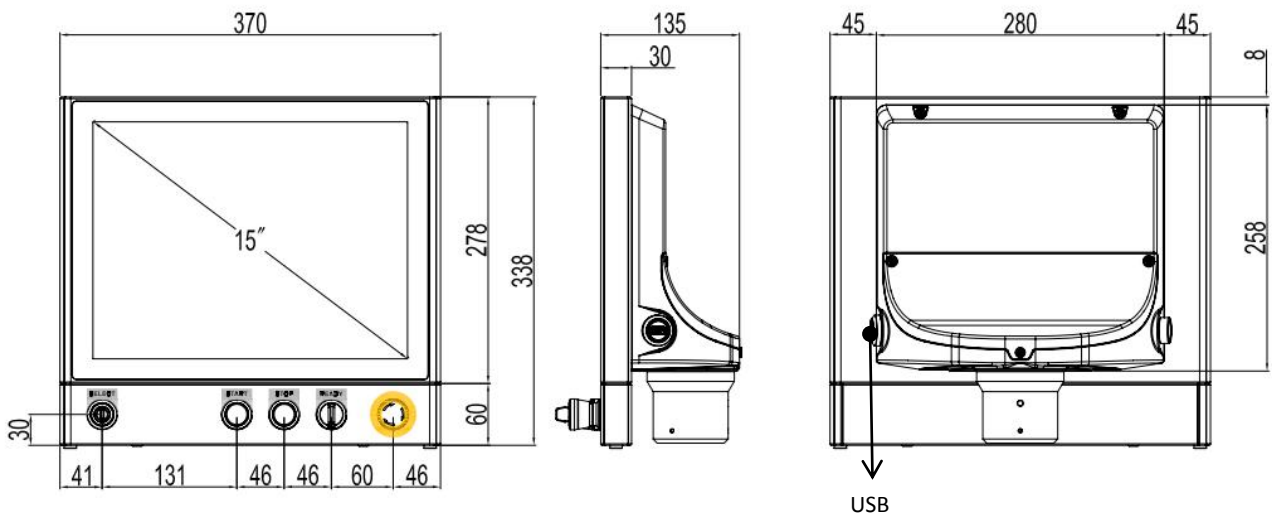

## ■ Internal I/O

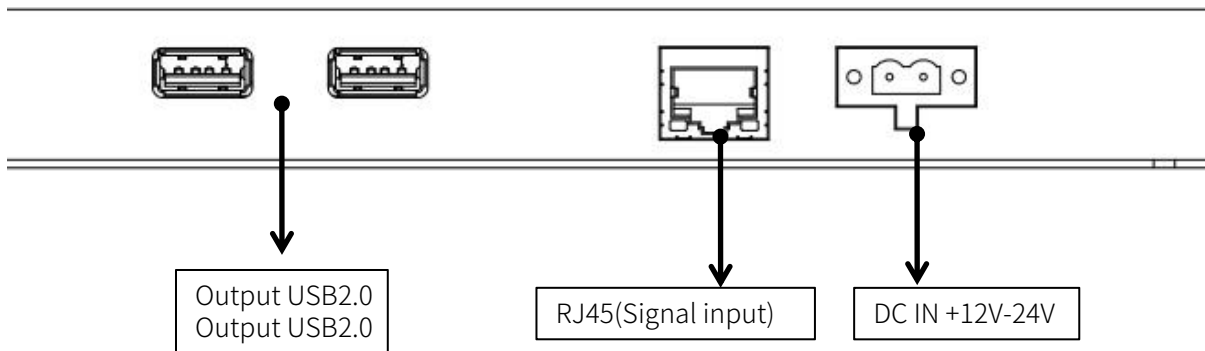

## ■ Ordering Information

P/N	Product name	Description
	IDP59150-C-HA	15.0", 1024*768, Capacitive Touchscreen, Remote display, 2*USB2.0, DC 12V-24V, ARM mounting

## ■ Optional Accessories

Option items	Description
USB cable	USB2.0 TypeA to TypeB cable optional 1.5m
DVI cable	DVI to HDMI cable optional 1.5m
Remote TX BOX	link-200
...	

Note: If the system provides some optional parts, additional certification of system compatibility may be required in some regions/countries, please contact NODKA for system compatibility.

## ■ Application 1

- With the NODKA product ebox-3625 ,connect the PC to the monitor using a network cable of CAT6A specifications or higher,realize the transmission of display signal and USB signal



**NOTICE:**

The network cable used must reach cat6 or above, and the longer the distance, the higher the standard network cable must be used.

## ■ Application 2

- Industrial PC with DVI-D/HDMI interface,transmitter Box elink-200,connect the PC to the monitor using a network cable of CAT6A specifications or higher,realize the transmission of display signal and USB signal

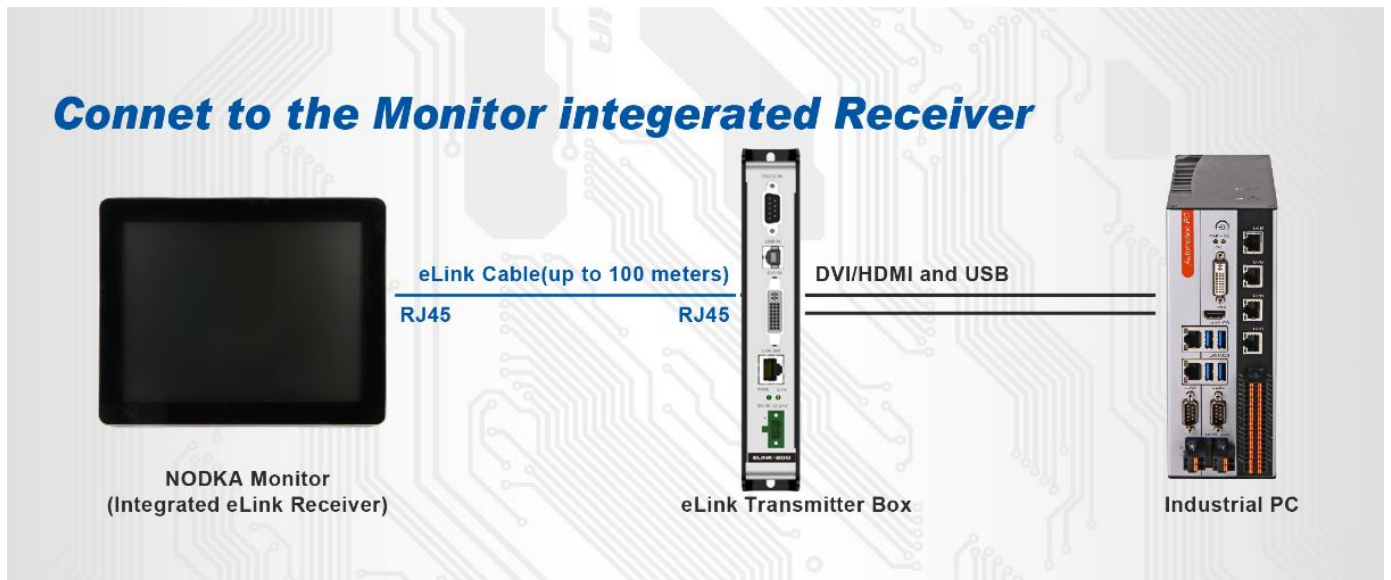

**NOTICE:**

The network cable used must reach cat6 or above, and the longer the distance, the higher the standard network cable must be used.