

ICP69215-C-H3-2Y/4Y-N305

■ Arm mounting PC

■ Features

- 21.5" LCD,1920*1080,resolution,Multi-touch,Capacitive Touchscreen
- Full IP65 design
- 2/4*Glan/4*USB3.0/1*HDMI/2*COM
- DC12-24V power input
- Support ARM mounting from TOP side or BOTTOM side
- Fanless and anodized aluminum
- Customer-specific requests for button units,up to 9x Ø22 buttons
- 1x power switch and 1x 2in1 USB 2.0 port at the back side



■ Specificatio

Product Name		ICP69215-C-H3-2Y-N305	ICP69215-C-H3-4Y-N305
LCD	Size	21.5" LCD	
	Resolution ratio	1920*1080	
	White Luminance	250cd/m2	
	MTBF (hour)	50000hrs	
	Contrast Ratio	1000:1	
	Viewing Angle	(L)89 / (R)89 / (T)89 / (B)89	
Mechanical	Dimensions (W x H x D)	553mm x 387.5mm x 135mm	
	Installation	Swing ARM mounting (Support NODKA 4460 square tube and Rittal CP 40)	
	Buttons	Default: 1x Emergency button, 1x selection button, 1x red push button, 1x green push button, 1x Key switch	
	Weight	7.7Kg	
System	CPU	Intel® Core™ i3 processor N Series N305 (6 M Cache , 1.80 GHz up to 3.80 GHz), TDP15W	
	Memory	1x DDR4/DDR5 , Max support 16GB , Maximum Memory Speed 4800 MHz	
	Storage	1 x 2.5" HDD/SSD + 1 x mSATA	
	Network(LAN)	2 x Intel 1000Mbps Ethernet	4 x Intel 1000Mbps Ethernet
	HDMI	HDMI1.2	
	Serial ports	2 X RS232/485(optional) , 2x 3-pins Phoenix Connector	
	USB	4 x USB3.0/2.0/1.0	
Touch screen	Touch screen type	Capacitive Touch screen	
	Communication interface	USB	
	Transmittance	≥87%	
OS	OS	Windows 7, Windows 10 IoT, Ubuntu, CentOS,	
Power Consumption	Input Voltage	12-24VDC ± 10% , Support reverse connection protection, over voltage protection, over current protection 1x 2-pins Phoenix Connector for DC power(internal); 1x Power button with light at the back of housing	
	Idle Power Consumption	Minimum 25W	
Environment	Operating Temperature	0°C ~ 50°C for SSD , 0°C ~ 45°C for HDD	
	Storage Temperature	-20°C ~ 60°C	
	Humidity	5~95% @ 40°C (non-condensing)	
	Vibration	SSD applied: 1.5 Grms, IEC 60068-2-64, random, 5 ~ 500 Hz, 1 hr/axis	
	Shock	Operating 10G peak acceleration (11ms duration), follow IEC 60068-2-27	
	EMC	Class B	
	Water-proof	Full IP65 compliant	

■ Dimensions (unit: mm) 21.5"

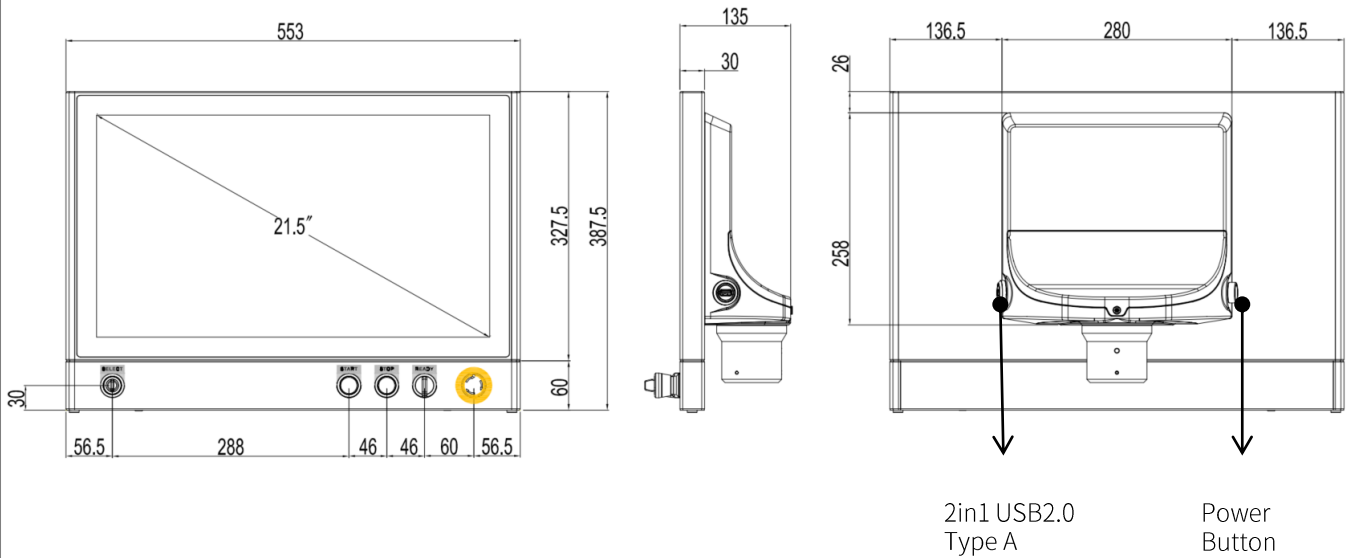

■ Internal I/O

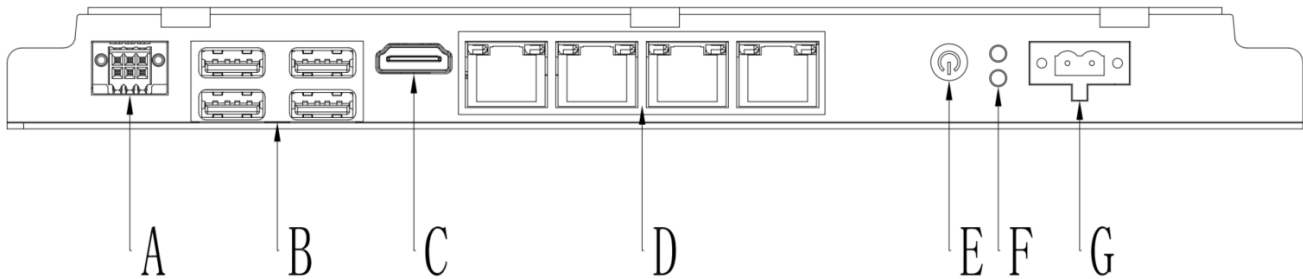

- A: 2*RS232/485
- B: 4*USB3.0
- C: HDMI
- D: 4*LAN
- E: Power button
- F: HDD/Power LEDs
- G: DC-in

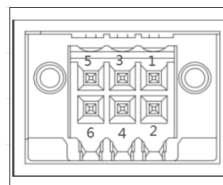

Pin	Definitio	Pin	Definitio
1	TX1/A1	2	GND
3	RX1/B1	4	TX2/A2
5	RX2/B2	6	END

■ Button Area



note:

1. Fully configurable according to customer specifications
2. Frontally accessible for subsequent configuration changes and/or additions
3. Hard-wired connection mode
4. The number of elements that can be installed depends on the size of the display
5. Technical Supports: www.nodka.com

■ Ordering Information

P/N	Product name	Description
	ICP69215-C-H3-4Y-N305	21.5", 1920*1080, 4*GigE lan, 4*USB3.0, 1*HDMI, 2*COM, 12V-24V
	ICP69215-C-H3-2Y-N305	21.5", 1920*1080, 2*GigE lan, 4*USB3.0, 1*HDMI, 2*COM, 12V-24V

■ Optional Accessories

Option items	Description
CPU	Intel® Core™ i3 processor N Series N305 (6 M Cache, 1.80 GHz up to 3.80 GHz), TDP15W Please contact sales to check other request.
Memory	DDR4 / DDR5 4G/8G/16G
Storage	Mini SATA SSD 64G/128G/256G/512G/1TB
	M.2 SSD 128GB,256GB,512GB,1TB,2TB
WiFi module	WiFi, 7260AN, folded cylinder TR tube
handle	Oval handle
keyboard holder	keyboard holder

Note: If the system provides some optional parts, additional certification of system compatibility may be required in some regions/countries, please contact NODKA for system compatibility.