

ICP69150-C-H51-2Y/4Y

■ Arm mounting PC

■ Features

- 15"LCD,1024*768,resolution,Multi-touch,Capacitive Touchscreen
- Full IP65 design
- 2/4*Glan/4*USB3.0/1*HDMI/2*COM
- DC12-24V power input
- Support ARM mounting from TOP side or BOTTOM side
- Fanless and anodized aluminum
- Customer-specific requests for button units,up to 6x Ø22 buttons
- 1x power switch and 1x 2in1 USB 2.0 port at the back side



■ Specification

Product Name		ICP69150-C-H51-2Y	ICP69150-C-H51-4Y
LCD	Size	15"LCD	
	Resolution ratio	1024*768	
	White Luminance	400cd/m2	
	MTBF (hour)	50000hrs	
	Contrast Ratio	1000:1	
	Viewing Angle	(L)89 / (R)89 / (T)89 / (B)89	
Mechanical	Dimensions (W x H x D)	370mm x 338mm x 135mm	
	Installation	Swing ARM mounting (Support NODKA 4460 square tube and Rittal CP 40)	
	Buttons	Default: 1x Emergency button, 1x selection button, 1x red push button, 1x green push button, 1x Key switch	
	Weight	6.6Kg	
System	CPU	Intel® Core™ 6th/7th/8th/9th i5/i3 and pentium/celeron LGA 1151 type CPU. Max.35W TDP	
	Memory	2 x 260-pin DDR4 SODIMM, Max support 32GB	
	Storage	1 x 2.5"HDD/SSD + 1 x mSATA	
	Network(LAN)	2 x Intel 1000Mbps Ethernet	4 x Intel 1000Mbps Ethernet
	HDMI	HDMI1.2	
	Serial ports	2 X RS232/485(optional),2x 3-pins Phoenix Connector	
	USB	4 x USB3.0/2.0/1.0	
Touch screen	Touch screen type	Capacitive Touch screen	
	Communication interface	USB	
	Transmittance	≥80%	
OS	OS		Windows 7, Windows 10 IoT, Ubuntu, CentOS,
Power Consumption	Input Voltage	12-24VDC ±10% , Support reverse connection protection, over voltage protection, over current protection 1x 2-pins Phoenix Connector for DC power(internal); 1x Power button with light at the back of housing	
	Idle Power Consumption	Minimum 35W	
Environment	Operating Temperature	0°C ~ 50°C for SSD , 0°C ~ 45°C for HDD	
	Storage Temperature	-20°C ~ 60°C	
	Humidity	5~95% @ 40°C (non-condensing)	
	Vibration	SSD applied: 1.5 Grms, IEC 60068-2-64, random, 5 ~ 500 Hz, 1 hr/axis	
	Shock	Operating 10G peak acceleration (11ms duration), follow IEC 60068-2-27	
	EMC	Class B	
Water-proof	Full IP65		

■ Dimensions (unit : mm) 15"

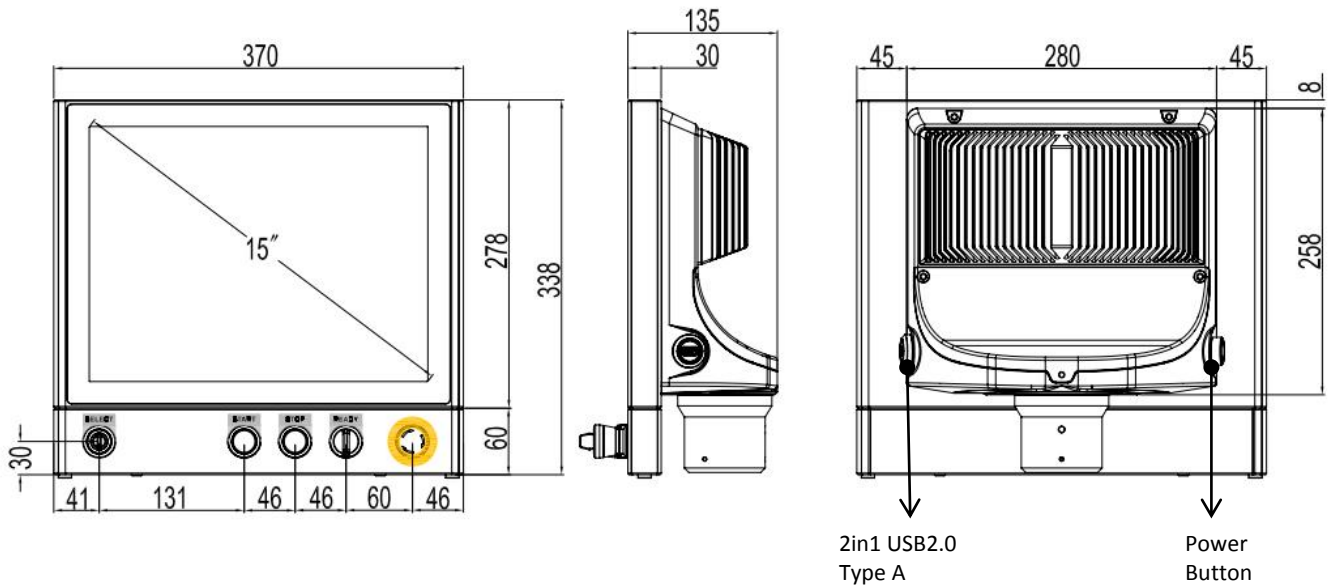

■ Internal I/O

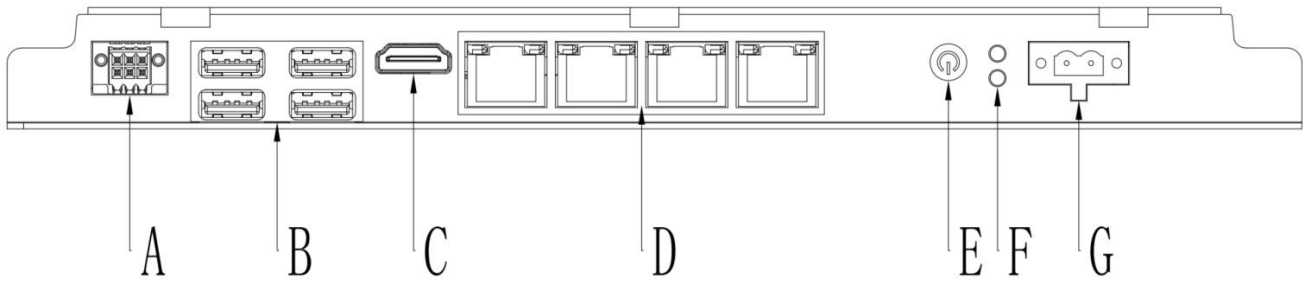

- A: 2*RS232/485
- B: 4*USB3.0
- C: HDMI
- D: 4*LAN
- E: Power button
- F: HDD/Power LEDs
- G: DC-in

■ Button Area



note :

1. Fully configurable according to customer specifications
2. Frontally accessible for subsequent configuration changes and/or additions
3. Hard-wired connection mode
4. The number of elements that can be installed depends on the size of the display
5. Technical Supports : www.nodka.com

■ Ordering Information

P/N	Product name	Description
	ICP69150-C-H51-4Y	15", 1024*768, 4*GigE lan, 4*USB3.0, 1*HDMI, 2*COM, 12V-24V
	ICP69150-C-H51-2Y	15", 1024*768, 2*GigE lan, 4*USB3.0, 1*HDMI, 2*COM, 12V-24V

■ Optional Accessories

Option items	Description
CPU	Support 6th/7th/8th/9th generation Intel® Core™ i5/i3 LGA 1151 socket type processors Intel® Core™ i5-6500T, Quad Core, 2.5GHz, 6MB Cache Intel® Core™ i5-6400T, Quad Core, 2.2GHz, 6MB Cache Intel® Core™ i3-6100T, Two Core, 3.2GHz, 3MB Cache Intel® Core™ i5-7400T, Quad Core, 2.4GHz, 6MB Cache Intel® Core™ i5-7500T, Quad Core, 2.7GHz, 6MB Cache Please contact sales to check other request.
Memory	DDR4 4G/8G/16G
Storage	Mini SATA SSD 64G/128G/256G/512G/1TB
	M.2 SSD 128GB,256GB,512GB,1TB,2TB

Note: If the system provides some optional parts, additional certification of system compatibility may be required in some regions/countries, please contact NODKA for system compatibility.