

NP-6111-L2

- Fanless, Low power consumption
- 2 x RS-232/485, 4 x Intel GbE LAN

■ Features

- 4 x Intel GbE LAN controller
- 4 x USB on the front, 1 x USB2.0 on board for USB dongle
- 2 x RS232/485, RS485 support auto flow control
- DC12~24V Power supply with overcurrent, overvoltage and polarity inverse protection
- Support wall-mounted or DIN-Rail fixing style
- Fully enclosed structure, fanless design
- Wide operating temperature -20 ~ 60°C supported



■ Specifications

| Model Name | | NP-6111-L2-J1900 | NP-6111-L2-J6412 | NP-6111-L2-N305 | NP-6111-L2-N97 |
|-------------|---------------------|---|---|---|---|
| System | CPU | Intel® Celeron J1900, 2.0GHz, 4 cores/4 threads, 2MB L2 cache | Intel® Celeron J6412, 2.0~2.6GHz, 4 cores/4 threads, 1.5MB L2 cache | intel® Core i3-N305, 8 cores/8 threads, 6M Intel® Smart Cache, up to 3.8GHz | Intel® Processor N97, 4 cores, 6MB Intel® Smart Cache, up to 3.6GHz |
| | TDP | 10W | | 15W | 12W |
| | BIOS | AMI UEFI BIOS | | | |
| | Memory | 1 x SO-DIMM DDR3L-1333MHz (max. 8GB) | 1 x SO-DIMM DDR4-2400MHz (max. 16GB) | 1 x SO-DIMM DDR5-4800MHz (max. 16GB) | |
| | Storage | 1 x mSATA bay | | | |
| | USB | 1 x USB3.0, 3 x USB2.0 | 2 x USB3.0, 2 x USB2.0 1 x USB2.0 Type A on the board for USB dongle | | |
| | COM | 2 x COM(DB-9), selectable to support RS232 or RS485 mode by the switch, RS485 support auto flow control, (ESD protection for RS232: Air gap ±8KV, Contact ±6KV) | | | |
| | Ethernet | 4 x Intel GbE LAN controller | | | |
| | DVI-D | Support up to 1920 x 1080 @ 60Hz | | | |
| | Watch Dog | 1~255 levels programmable | | | |
| OS Support | Microsoft Windows | Windows 10 IoT | | | |
| | Linux | Ubuntu, CentOS, Debian | | | |
| Power | Voltage Input | DC12~24V ±10%, overcurrent, overvoltage and polarity inverse protection | | | |
| | Power Consumption | Max. 60W | | | |
| Chassis | Structure | Aluminum-magnesium alloy box, Fanless, Wall-mounted or DIN-Rail | | | |
| | Dimensions | (L)200mm x (W)154.5mm x (H)74.6mm | | | |
| | Net Weight | 1.8Kg | | | |
| Environment | Work Temperature | -20°C ~ 60°C (-4°F ~ 140°F) with air flow (SSD) | | | |
| | Storage Temperature | -40°C ~ 80°C (-40°F ~ 176°F) with air flow (SSD) | | | |
| | Relative Humidity | 5~95% (Non-condensing) | | | |
| | Operating Vibration | 5~500Hz, 1.5Grms@with SSD, Follow IEC60068-2-64 | | | |
| | Operating Shock | 20G peak acceleration(11ms duration) with SSD, Follow IEC60068-2-27 | | | |
| | EMC | CE/FCC Class A | | | |

■ Dimensions (Unit: mm)

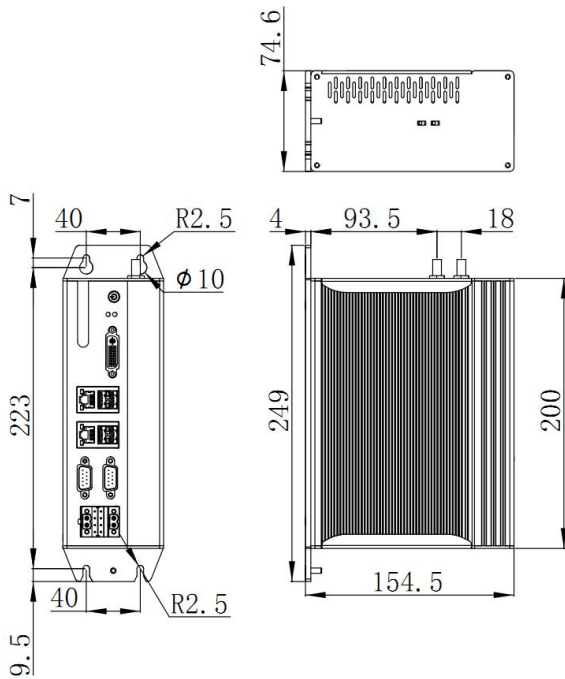

■ Interfaces

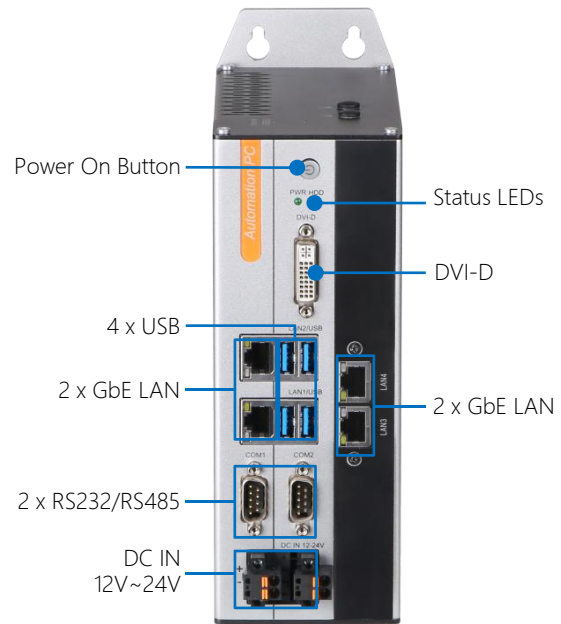

■ Ordering Information

| Part No. | Product | Description |
|-------------------|------------------|--|
| B73.61110.0E.0001 | NP-6111-L2-J1900 | CPU:J1900, RAM:NULL, mSATA: NULL, 2 x COM(RS232/485 selectable), 4 x LAN,1 x USB3.0, 3 x USB2.0, DVI-D, DC12~24V Power input |
| B73.61110.0E.0006 | NP-6111-L2-J6412 | CPU:J6412, RAM:NULL, mSATA: NULL, 2 x COM(RS232/485 selectable), 4 x LAN,2 x USB3.0, 2 x USB2.0, DVI-D, DC12~24V Power input |
| B73.61110.0E.0008 | NP-6111-L2-N305 | CPU:N305, RAM:NULL, mSATA: NULL, 2 x COM(RS232/485 selectable), 4 x LAN,2 x USB3.0, 2 x USB2.0, DVI-D, DC12~24V Power input |
| B73.61110.0E.0009 | NP-6111-L2-N97 | CPU:N97, RAM:NULL, mSATA: NULL, 2 x COM(RS232/485 selectable), 4 x LAN,2 x USB3.0, 2 x USB2.0, DVI-D, DC12~24V Power input |

■ Options

| Parts | Description |
|--------------|--------------------------------|
| DDR3L Memory | DDR3L-1333MHz: 4GB, 8GB |
| DDR4 Memory | DDR4-2400MHz: 4GB, 8GB, 16GB |
| DDR5 Memory | DDR5-4800MHz: 8GB, 16GB |
| mSATA SSD | 64GB, 128GB, 256GB, 512GB, 1TB |
| Mount Option | DIN-Rail |

Note: If some optional parts are offered with the system, additional system certificates may be required in certain regions/countries. Please contact NODKA for certificate compliance.